

RIGHT SIDE

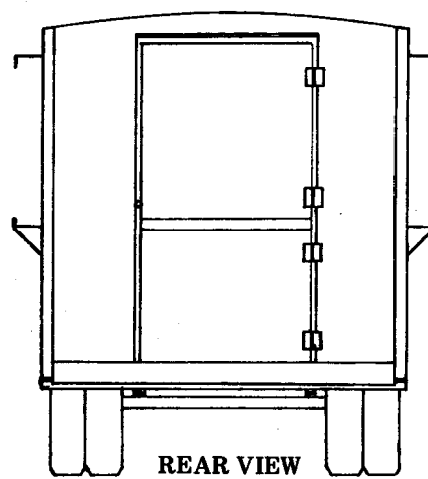

REAR VIEW

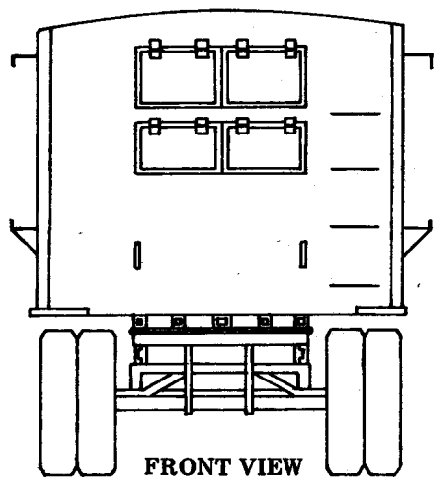

FRONT VIEW

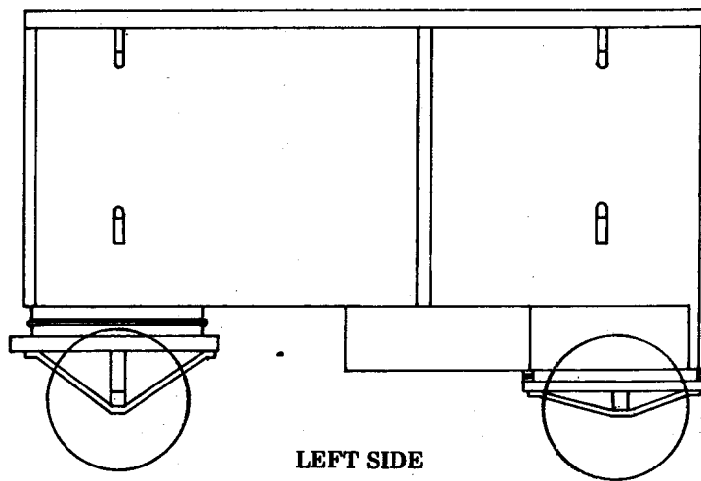

LEFT SIDE

Wagon #14 was of metal construction with a wooden floor. The number 14 on the Ringling show was usually associated with the Commissary or general store for the circus employees. There were shelves along the inside walls where personal supplies and tobacco could be purchased. Workmen would sign a special card and the amount of their purchase would be punched accordingly. These cards were usually in \$2.00 denominations and this amount would be deducted from their pay.

The former commissary was a much larger wagon and the one that replaced this wagon in the 1950's was the wagon that carried the sound equipment in the 1940's.

The wagon is now located at the Circus World Museum in Baraboo, Wisconsin.

Dimensions

- 14' 0" Long
- 7' 6" Wide
- 5' 9" High, Front side
- 7' 0" High, Rear side

Painted gree, a somewhat darker shade than was used on the Dining department wagons during the 1950s.

RBBB			
Commissary Wagon No. 14			
DATE: 1950s	SCALE: 1/4" = 1'	SCANNED & REVISED: 09/30/2004	Pg 1 of 2
Circus Model Builders			DRAWING NUMBER
Drawn By Jim Caldwell			#0249



Left side of No. 14 at Sarasota, winter quarters. [Reynolds Photo]



Right side of the wagon taken at Springfield, Ohio. [Caldwell Photo]



Two views of the rear of No. 14. [Caldwell Photos]



Left side of No. 14 at winter quarters. [Reynolds Photo, Caldwell Collection]



Former sound amplifier 104, used as the commissary wagon replacing the one above, until the show closed in 1956, the last season under canvas. [Reynolds Photo, DeWitt Collection]

RBBB			
Commissary Wagon No. 14			
Pg 2 of 2	SCALE: 1/4" = 1'	SCANNED & REVISED: 09/30/2004	DRAWING NUMBER #0249