

This is a detailed drawing showing the manner of finishing the largest tops at eave. The location of side poles is shown by the rings at "A" which are utilized if forming the holes admitting the spindle of uprights. The lining at eave consists of a full breadth of goods, and the side pole holes are placed from 12 to 2 inches back from the extremity of eave, to which the scalloped border is attached.

Five ropes are shown splicing around each ring. They consist of the section rope " " and its continuation to eave the sweep rope connections between side poles and one eave guy " " which increases the efficiency of the guys by distributing the strain so that one will draw directly from upright. The vacant spaces of the rings between the different splices are served with rope yarn to make the inside smooth and of equal diameter. A hole is then cut through the canvas, which is attached by starting around with twine, and finally finished with a covering of moistened leather. The short continuation of the section ropes is fitted with oval thimbles "C" into which a second eave guy is attached. The rope shown at the center of this section is finished in like manner and is also steadied with an eave guy. All roping, with exception of the lower eave rope " " is placed on the inside, and the thimbles, with the guys attached, lead through a small opening in the border to ground.

The guy ropes leading directly from the ring, " " also pass through the same opening and continue to the ground, after passing through the thimbles indicated by arrows "C." This permits the border to hang properly around tent without resting upon or coming in contact with any of the eave guy ropes. The walls of large tops are not fastened with snap-hooks and rings instead there is a lanyard to hoist at each side pole, a leader is seized to the section rope under the border at the extremity of the eave. This is shown at "B" and may consist of a round or oval thimble, although in many instances a leader in the form of a large -hook is used.

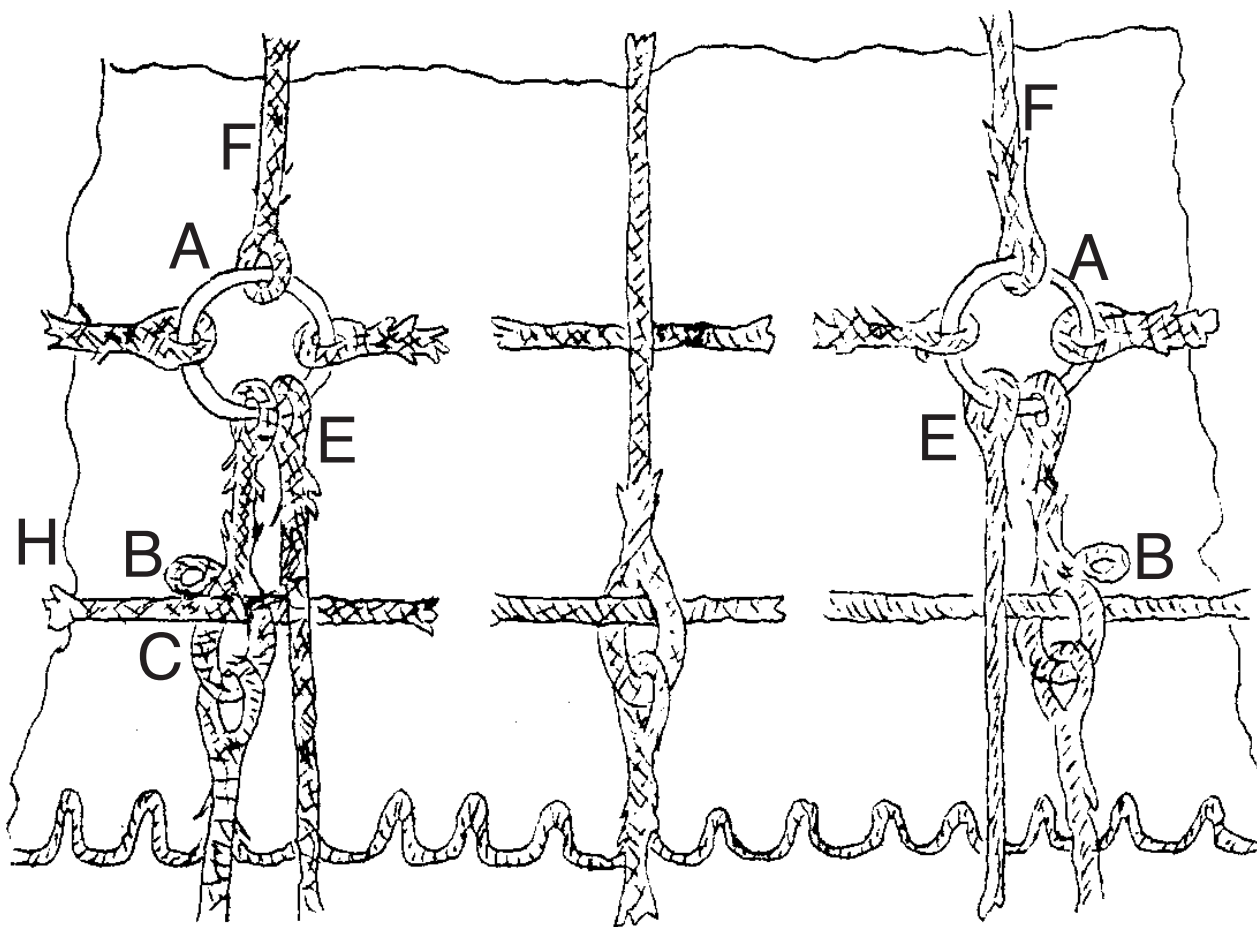

This drawing is not to scale

Tent - Finishing Large Top at Eaves & Roping at Bail Ring

DATE: 1940s

SCALE: None

SCANNED & REVISED:
12/30/01

Pg 1 of 3

Circus Model Builders

Drawn By
Lucky Allen & Steve Flint

DRAWING NUMBER

#0013

This shows the method of roping at the bail ring of a center piece, and round end piece.

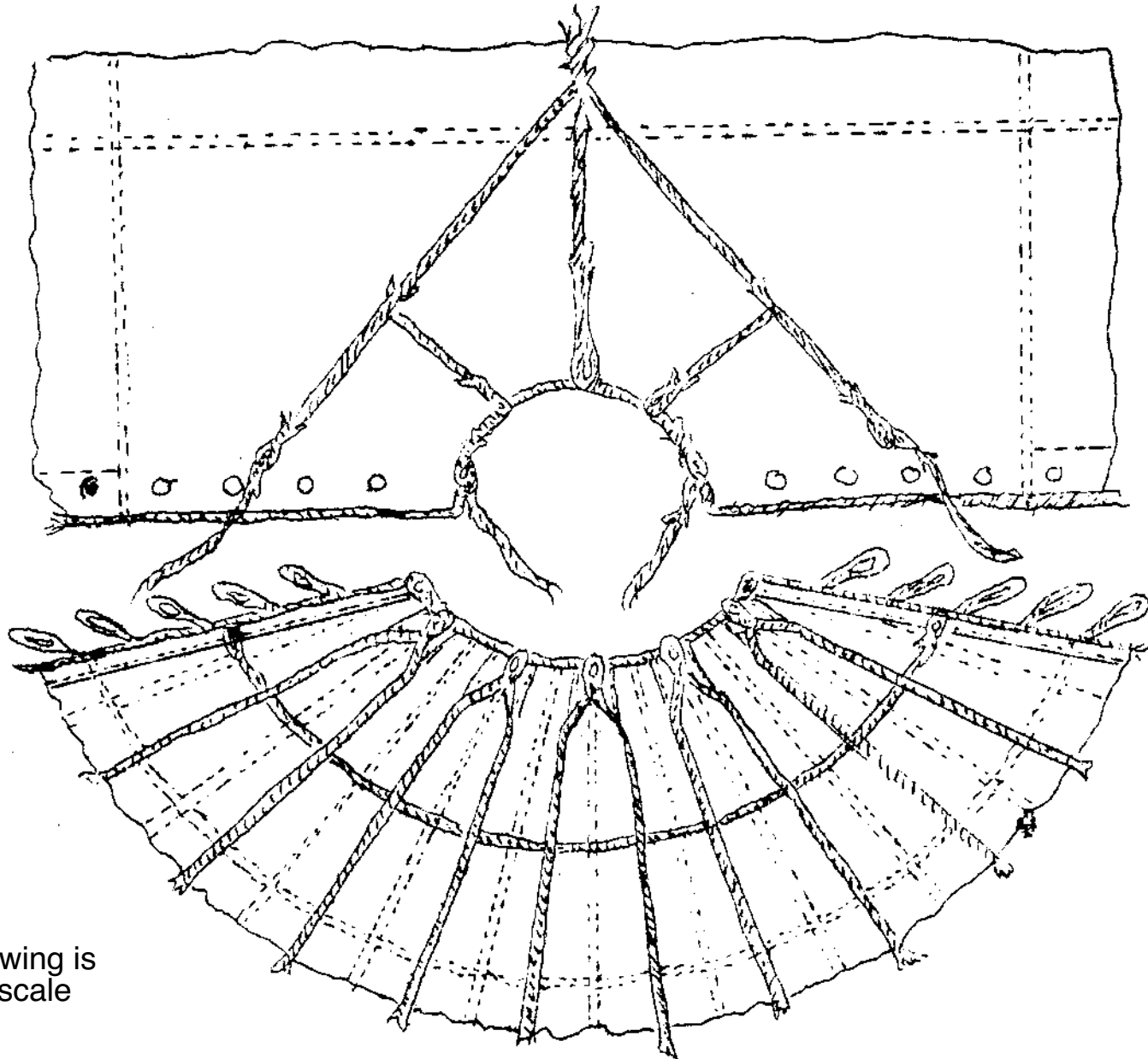

This drawing is
not to scale

**Tent - Finishing Large Top at Eaves &
Roping at Bail Ring**

Pg 2 of 3

SCALE:None

SCANNED & REVISED:
1230/01

DRAWING NUMBER
#0013

- X Rope
- S Stake
- L Holes on Lacing Strip
- R Reinforcements (These are a strip of canvas with a rope reinforcement sewed inside. Usually colored where the Quarter Poles are.)
- ST Storm Ropes (Used in bad weather only)
- SM Seam
- E Eave (Varies from 14" to 24")
- P Pole
- V Valance
- T Top of Canvas

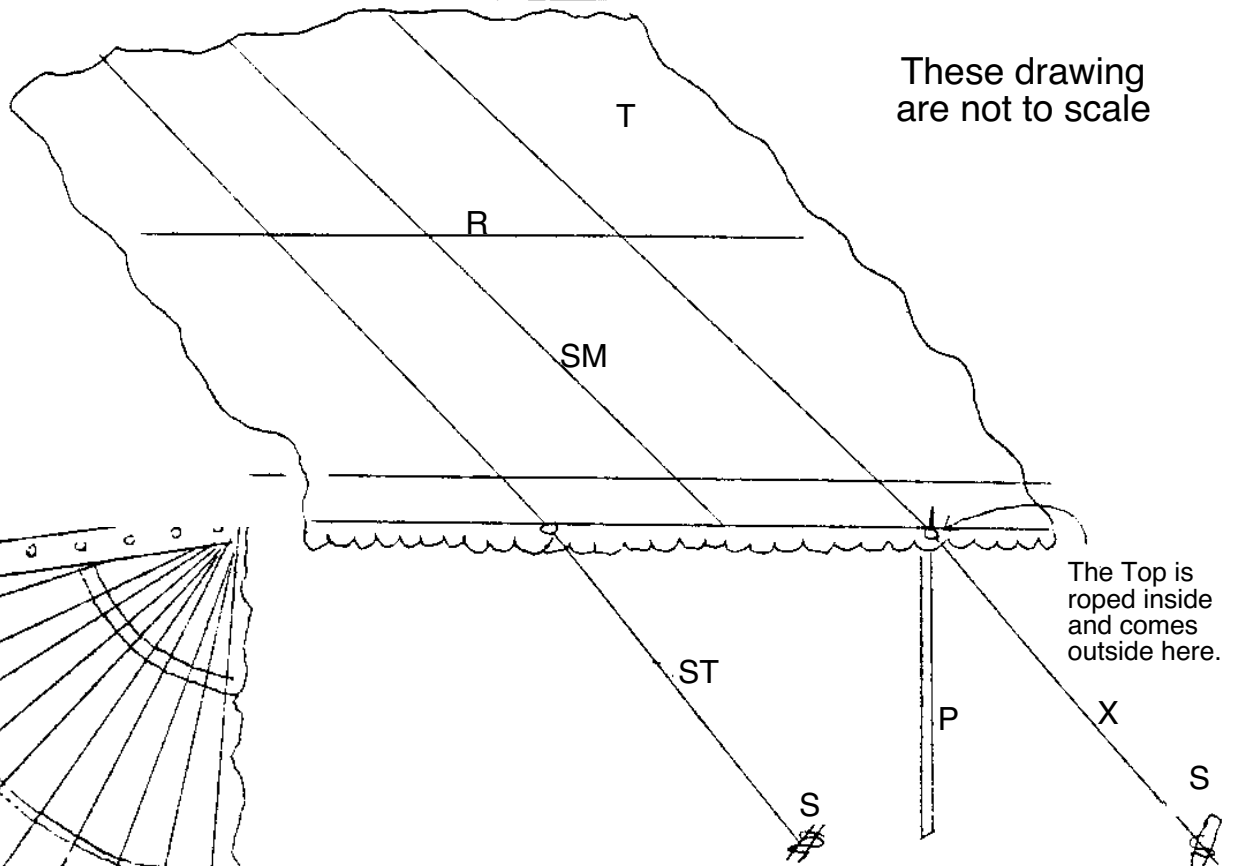

These drawing are not to scale

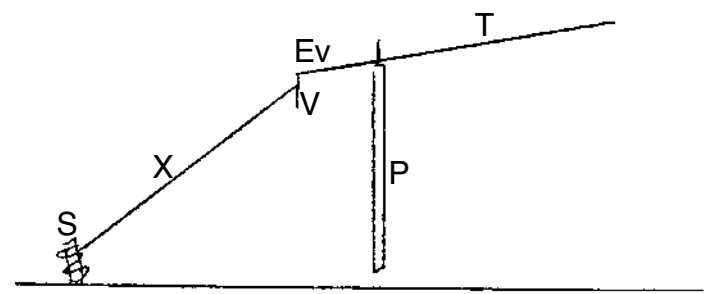
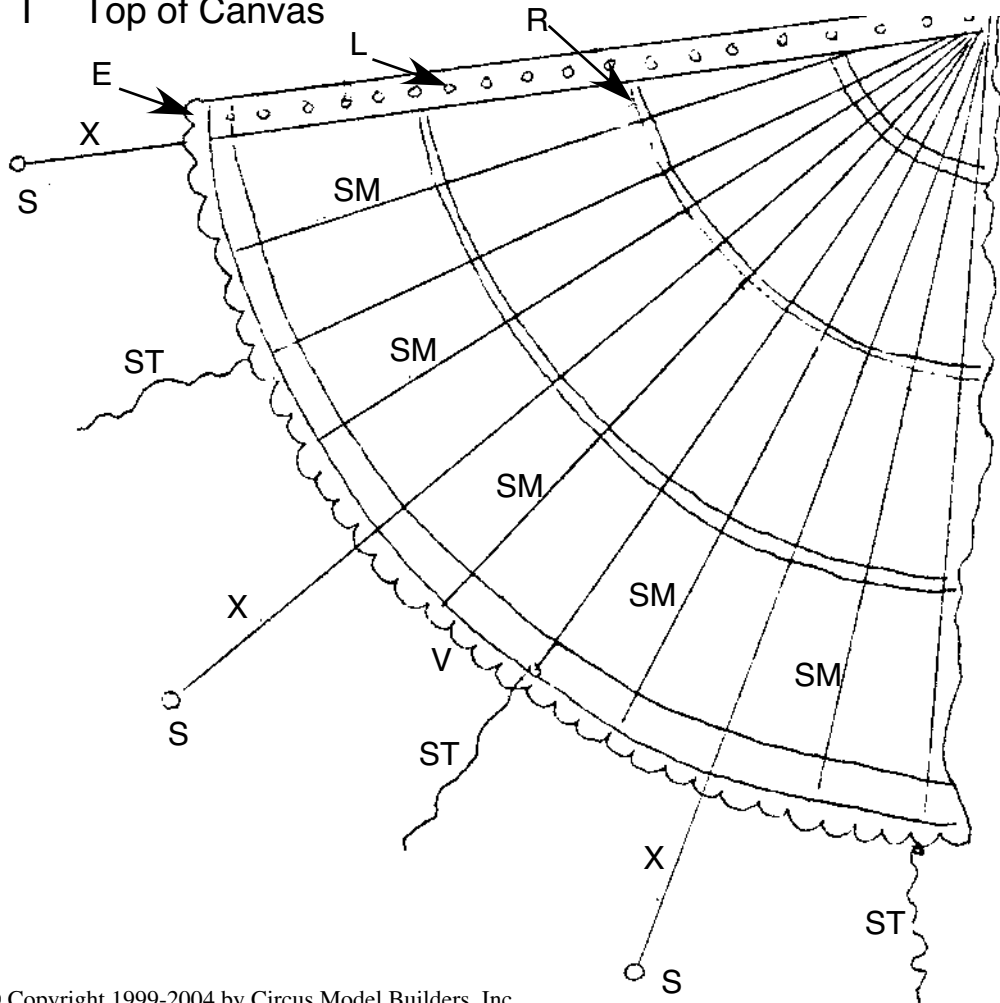

T

Tent - Finishing Large Top at Eaves & Roping at Bail Ring

| | | | |
|-----------|-------------|--------------------------------|-------------------------|
| Pg 3 of 3 | SCALE: None | SCANNED & REVISED: 12/30/01 | DRAWING NUMBER #0013 |
|-----------|-------------|--------------------------------|-------------------------|