

Side View

7' 6"

**Note:**

This wagon had 16 spoke wheels. Those shown are representations since the original drawing did not include the spokes and the wheels were barely visible.

Mike Dreiling, Superintendent of Plans, May 5, 2002

**Al G. Barnes  
Stake Driver**

DATE: 1930

SCALE: 1/2" = 1'

SCANNED & REVISED:  
05/05/02

Pg 1 of 3

**Circus Model Builders**

Drawn By  
Bill Cox, CMB 213

DRAWING NUMBER

**#0093**

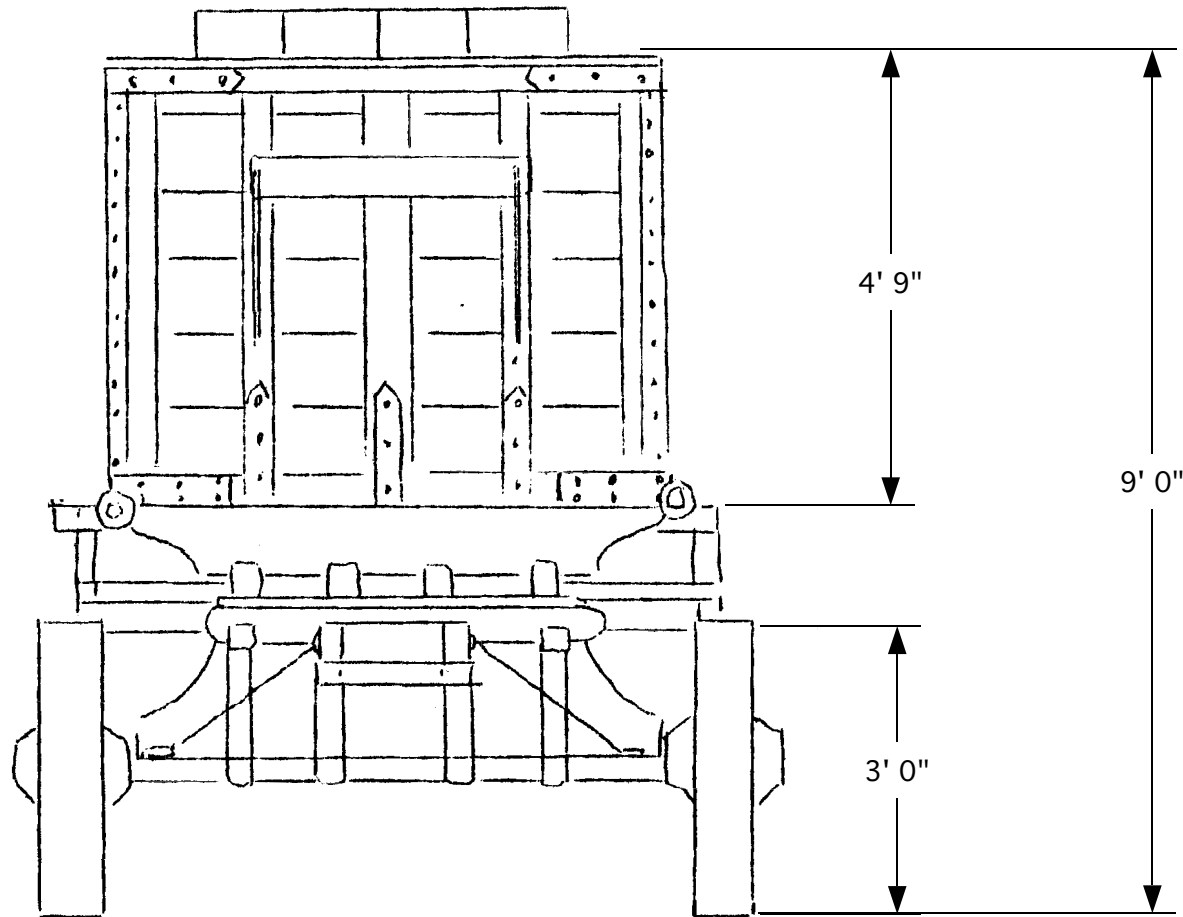

Front View

**Al G. Barnes  
Stake Driver**

Pg 2 of 3

SCALE: 1/2" = 1'

SCANNED & REVISED:  
05/05/02

DRAWING NUMBER  
**#0093**

**Note:**

Due to the poor condition of the copy available for scanning of this view of the drawing, this view was completely re-drawn. Extreme effort was made to convert the data as accurately as possible. All shown dimensions are as per the original.

Mike Dreiling, Superintendent of Plans, May 5, 2002

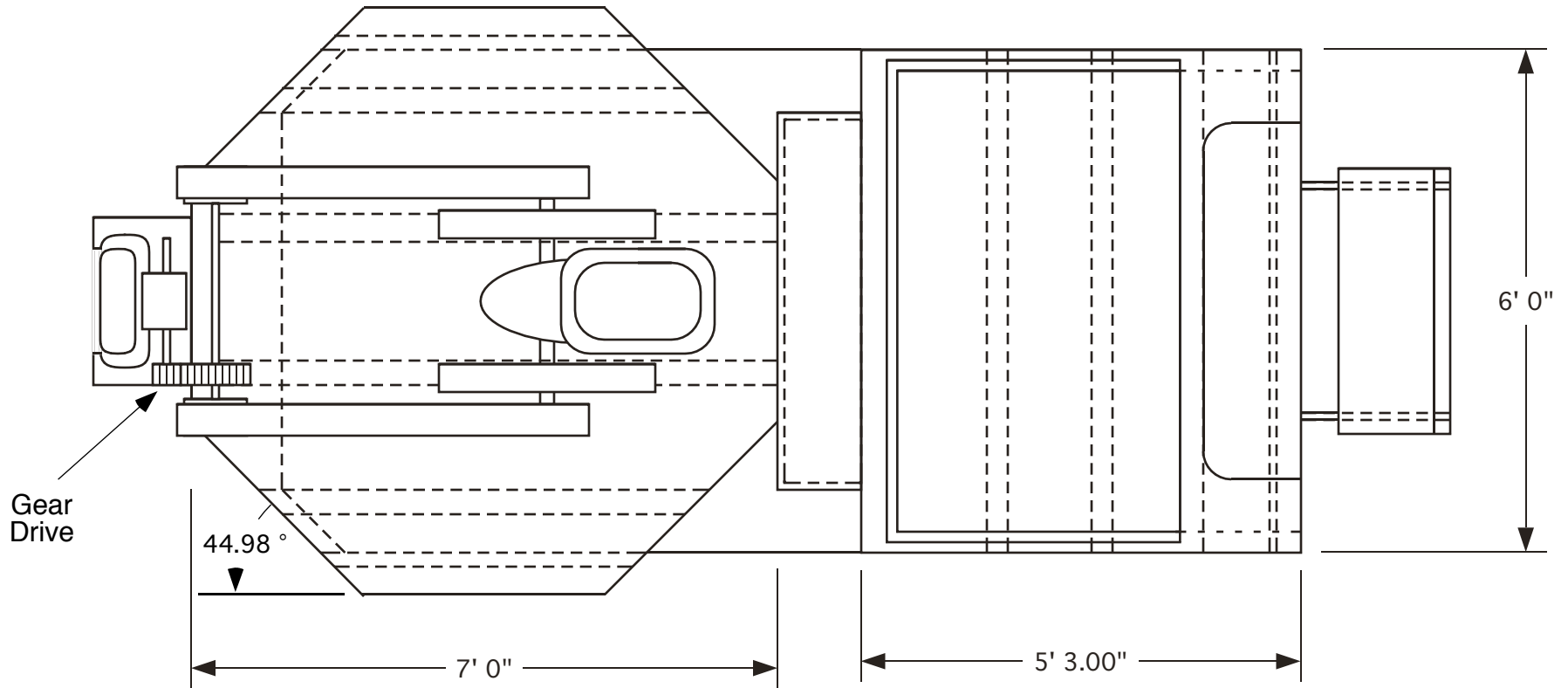

**Top View**

**Al G. Barnes  
Stake Driver**

Pg 2 of 3

SCALE: 1/2" = 1'

SCANNED & REVISED:  
05/05/02

DRAWING NUMBER  
**#0093**